

Preparation:

- 1. One side of the Dixon diameter tape is a standard measuring device. The other side is marked "INCHES OF DIA. BY 64 THS." (See "A" in Diagram 1). This side of the tape measures Outside Diameter (O.D.).
- 2. Review markings on the diameter tape:
 - a. The unmarked line to the right of the "INCHES OF DIA. BY 64THS" statement is the measurement line.
 - b. The number figures (1,2,3,etc.) with a line the width of the tape to the right of them indicate inches of diameter (See "B" in Diagram 1).
 - c. The number figures (16, 32 and 48) with a partial line below them are reference numbers. They identify $16/64^{\text{ths}}$, $32/64^{\text{ths}}$ and $48/64^{\text{ths}}$ of an inch respectively. (See "D" in Diagram 1).
 - d. The hash marks between the reference numbers represent $1/64^{\text{th}}$ of an inch. (See "C" in Diagram 1).

Notes:

- 1. Many Dixon clamping devices are selected based on the O.D. (Outside Diameter) of the hose they will be used on. Each clamp has a minimum and maximum O.D. range. To ensure proper coupling performance, it is imperative that the clamping device selected be the correct size for the hose O.D. being used.
- 2. Always measure the O.D. on both ends of the hose:
 - a. Manufacturers may change dimensional specifications on their products without notification.
 - b. Allowable manufacturing tolerances in the hose may effect clamping device selection.
- 3. It is good practice to measure each hose end twice to ensure an accurate measurement.

Process

- 1. Grasping the diameter tape buckle, pull several inches of tape from the case.
- 2. With the diameter side of the tape facing up, loop the tape around the end of the hose keeping the loop two to three inches from the hose end.
- 3. Keep the buckle to the bottom of the loop.
- 4. Pull the tape tight to the hose.
- 5. The measurement line will line-up with an inch of diameter mark, a reference number mark or a hash mark.

- ❑ 6. Read the hose O.D:
- If the measurement line lines-up with a reference number or a hash mark to the LEFT of the 1-inch of diameter number, the O.D. of the hose is a fraction. The fraction uses the number of hash marks as the numerator and 64 as the denominator.
 - If the measurement line lines-up with an inch of diameter number, the inches of diameter number is the O.D. of the hose. (See Diagram 2).
 - If the measurement line lines-up with a reference number to the RIGHT of the inches of diameter number, the hose O.D. is the inches of diameter number plus a fraction. The fraction uses the reference number as the numerator and 64 as the denominator. (See Diagram 3).
 - If the measurement line lines-up with a hash mark to the RIGHT of the inches of diameter number, the hose O.D. is the inches of diameter number plus a fraction. The fraction uses the number of hash marks to the RIGHT of the inches of diameter number as the numerator and 64 as the denominator. (See Diagram 4)

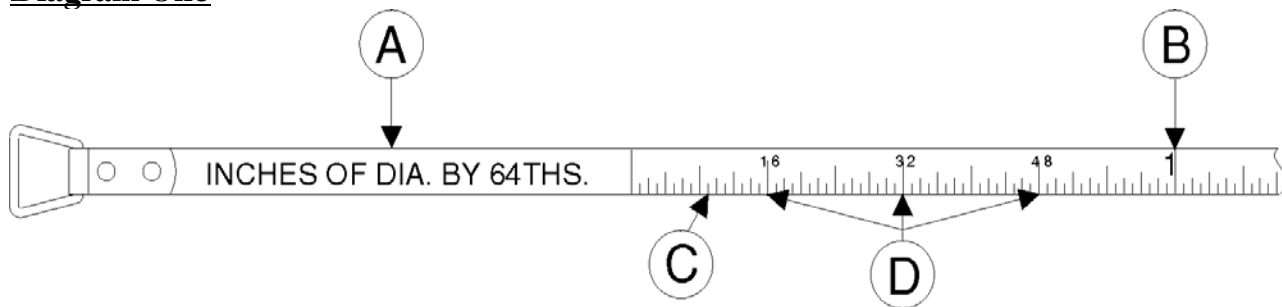
Diagram One

Diagram Two

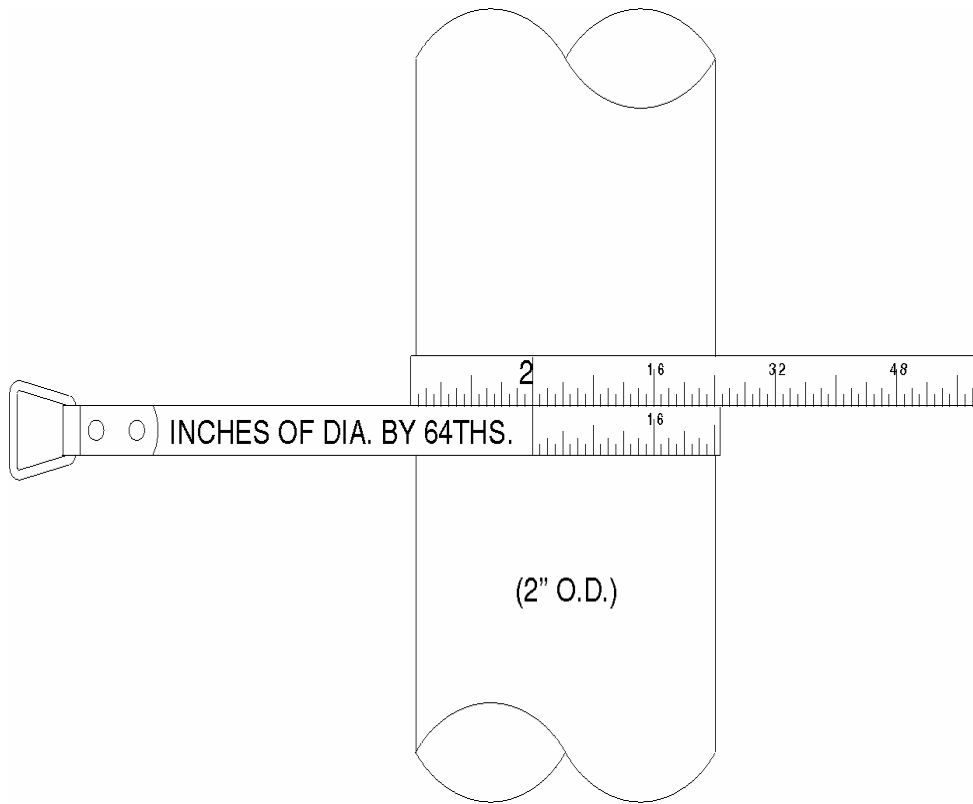


Diagram Three

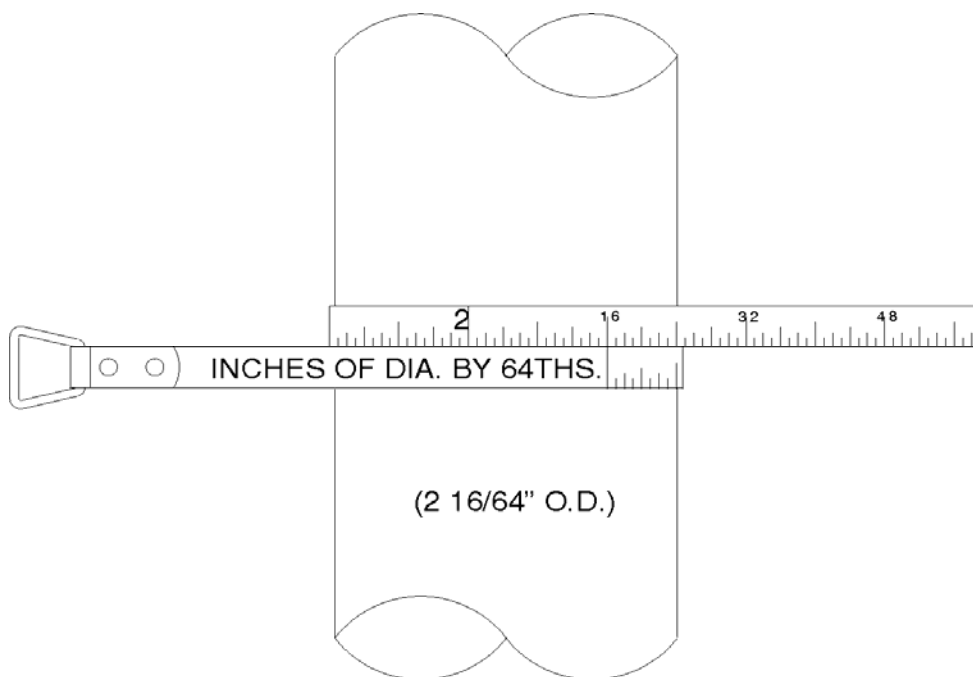


Diagram Four

