



## Product Configurator Sheet

# Dry Break Cam & Groove

Compatible with most cam and groove style dry disconnects. The Bayco dry disconnect helps prevent spillage from normal or accidental disconnects. A spring loaded sealing device is designed to "snap" closed should the valve become disconnected with the poppet open, significantly limiting liquid loss.

### Dry Break Couplers DBC series with Female NPT

example part # *DBC72-200*

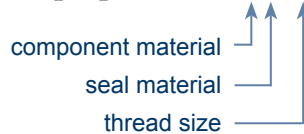

Dry Break Coupler with all stainless components, Viton® seals and 2" NPT thread

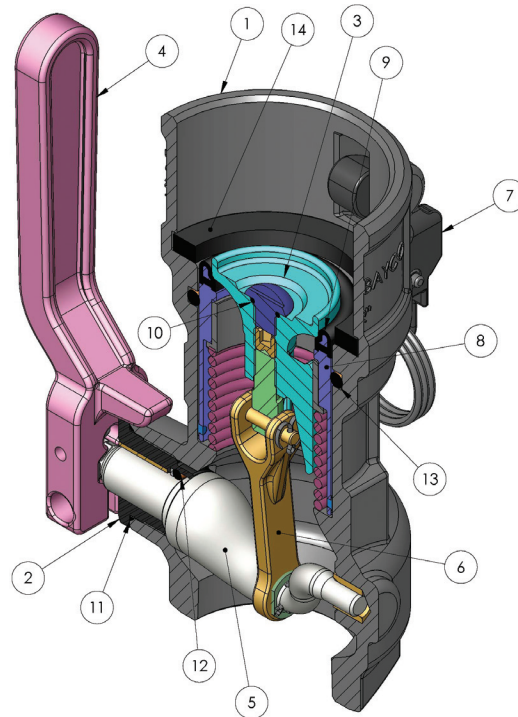

	Item	Description
Components	1	body
	2	stuffing box
	3	poppet
	4	handle
	5	crank
	6	link
	7	cam arm
	8	cylinder
Seals	9	nose seal
	10	screw O-ring
	11	stuffing box seal
	12	crank seal
	13	cylinder seal
	14	gasket

All metallic parts not listed are stainless steel.  
All non-metallic parts not listed are PTFE.

### Component Material

designation part number	body	stuffing box	poppet	handle	crank	link	cam arm	cylinder
6	aluminum	stainless steel	stainless steel	stainless steel	stainless steel	stainless steel	stainless steel	aluminum
7	stainless steel	stainless steel	stainless steel	stainless steel	stainless steel	stainless steel	stainless steel	stainless steel

### Seal Material

designation part number	nose seal	screw O-ring	stuffing box seal	crank seal	cylinder seal	gasket
1	buna	PTFE	PTFE	buna	buna	buna
2	Viton®	PTFE	PTFE	Viton®	Viton®	Viton®
3	PTFE	PTFE	PTFE	Kalrez®	PTFE encapsulated Silicone	PTFE encapsulated Silicone
4	EPDM	PTFE	PTFE	EPDM	EPDM	EPDM
6	PTFE	PTFE	PTFE	Kalrez®	Kalrez®	PTFE encapsulated Viton®
7	PTFE	PTFE	PTFE	Kalrez®	PTFE encapsulated Viton®	PTFE encapsulated Viton®
9	Viton® - B	PTFE	PTFE	Viton® - B	Viton® - B	Viton® - B

# Dry Break Couplers

## DBC series with Female NPT

example part # *DBC72-300*

component material  
 seal material  
 thread size

Dry Break Coupler with all stainless components, Viton® seals and 3" NPT thread

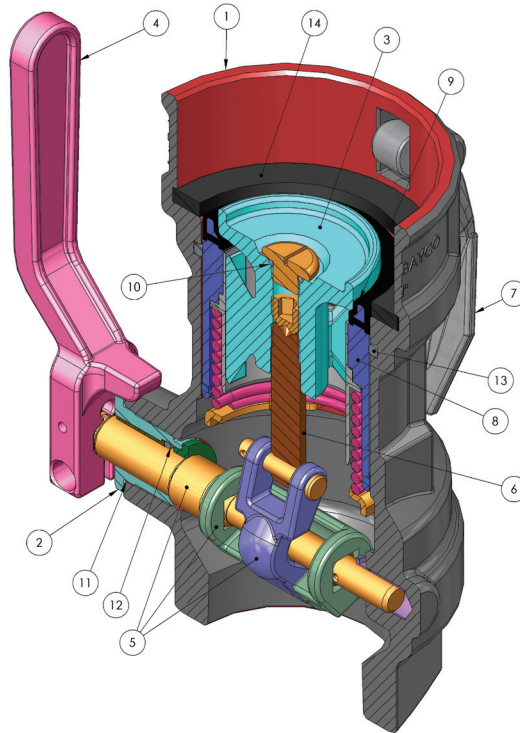

	Item	Description
Components	1	body
	2	stuffing box
	3	poppet
	4	handle
	5	crank
	6	link
	7	cam arm
	8	cylinder
Seals	9	nose seal
	10	screw O-ring
	11	stuffing box seal
	12	crank seal
	13	cylinder seal
	14	gasket

All metallic parts not listed are stainless steel.  
 All non-metallic parts not listed are PTFE.

### Component Material

designation part number	body	stuffing box	poppet	handle	crank	link	cam arm	cylinder
6	aluminum	stainless steel	stainless steel	stainless steel	stainless steel	stainless steel	stainless steel	aluminum
7	stainless steel	stainless steel	stainless steel	stainless steel	stainless steel	stainless steel	stainless steel	stainless steel

### Seal Material

designation part number	nose seal	screw O-ring	stuffing box seal	crank seal	cylinder seal	gasket
1	buna	PTFE	PTFE	buna	buna	buna
2	Viton®	PTFE	PTFE	Viton®	Viton®	Viton®
3	PTFE	PTFE	PTFE	Kalrez®	PTFE encapsulated Silicone	PTFE encapsulated Silicone
4	EPDM	PTFE	PTFE	EPDM	EPDM	EPDM
6	PTFE	PTFE	PTFE	Kalrez®	Kalrez®	PTFE encapsulated Viton®
7	PTFE	PTFE	PTFE	Kalrez®	PTFE encapsulated Viton®	PTFE encapsulated Viton®
9	Viton® - B	PTFE	PTFE	Viton® - B	Viton® - B	Viton® - B

**Dixon**  
 800 High Street  
 Chestertown, MD 21620

[www.dixonvalve.com](http://www.dixonvalve.com)  
 ph 800-355-1991  
 fx 800-283-4966