

THE INFORMATION CONTAINED IN THIS DRAWING IS THE SOLE PROPERTY OF DIXON BAYCO LIMITED. ANY REPRODUCTION IN PART OR WHOLE WITHOUT THE WRITTEN PERMISSION OF DIXON BAYCO LIMITED IS PROHIBITED.

REVISION TABLE				
REV.	ECO	DESCRIPTION	DATE	APPROVED
B	**	BOM & EXPLODED VIEW ADDED.	JUN 18/07	CM

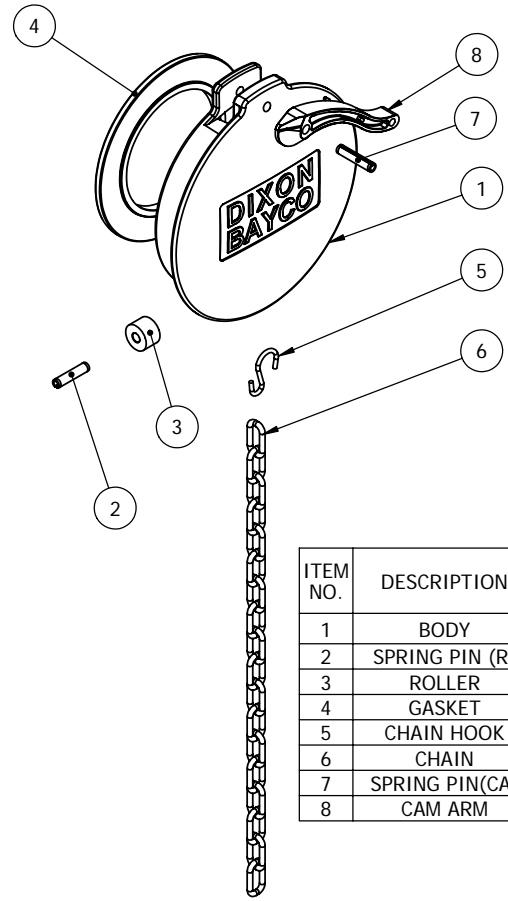
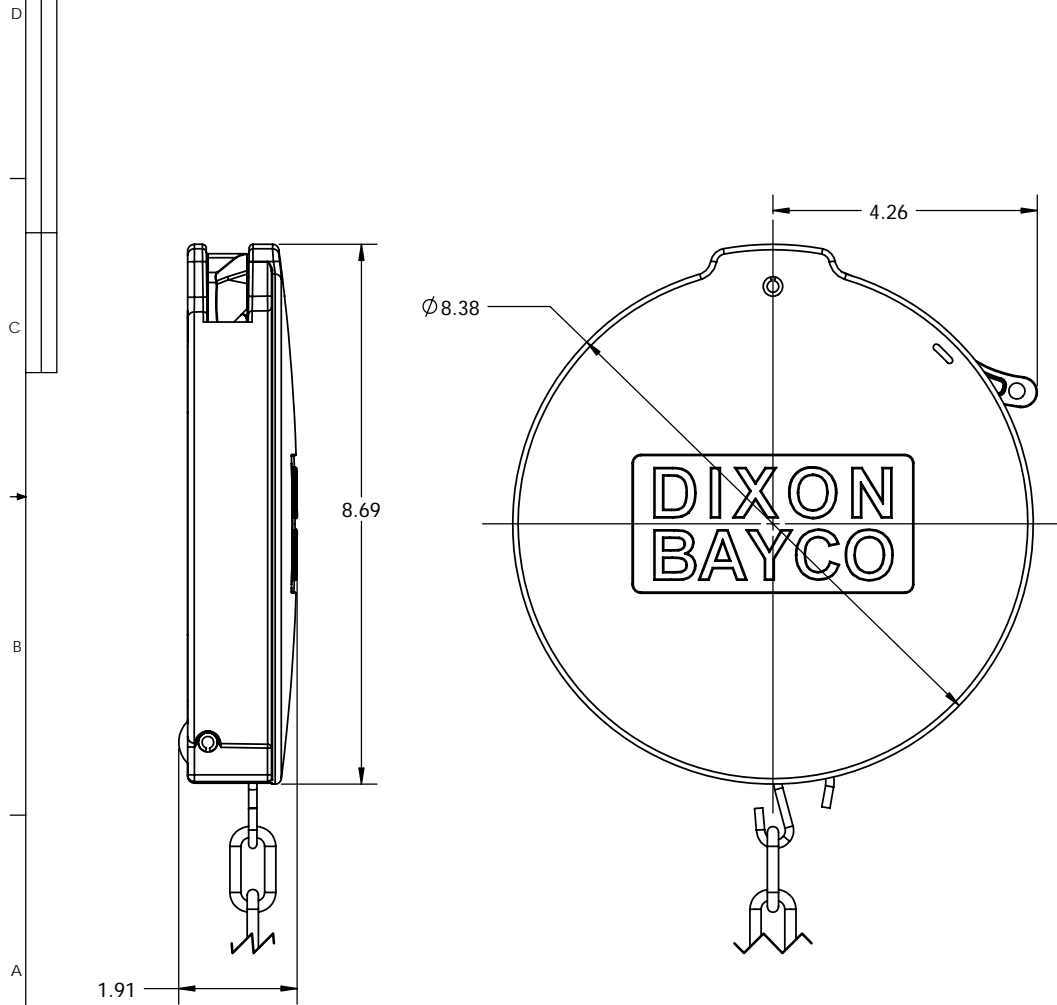

ITEM NO.	DESCRIPTION	MATERIAL	QTY
1	BODY	ALUMINUM	1
2	SPRING PIN (R)	STAINLESS STEEL	1
3	ROLLER	NYLON (BLACK)	1
4	GASKET	BUNA	1
5	CHAIN HOOK	ZINC PLATED STEEL	1
6	CHAIN	ZINC PLATED STEEL	1
7	SPRING PIN(CA)	STAINLESS STEEL	1
8	CAM ARM	NYLON (BLACK)	1

NOTES:
1. ALL SHARP EDGES AND BURRS TO BE REMOVED

DIMENSIONS ARE IN INCHES UNLESS OTHERWISE SPECIFIED
TOLERANCES ARE:
FRACTIONS DECIMALS ANGLES
± 1/16 XX ± .03 ± 1°
XXX ± .010



CAD GENERATED DRAWING. DO NOT MANUALLY UPDATE.
DO NOT SCALE DRAWING

MATERIAL	APPROVALS	DATE
	DRAWN BY F.FIDELINO	JAN 15/07
	CHECKED BY C.MARTENS	JAN 24/07

DIXON BAYCO LIMITED
2200 LOGAN AVE. WINNIPEG, MB. R2R 0J2
PHONE (204) 633-5650 FAX (204) 633-6119

TITLE API DUST CAP	
SIZE B	DWG. NO. 5205
ECO	CUSTOMER DRAWING
REV. B	SHEET 1 OF 1