

H:9B:CFA5HC B7CBH5B98-BH:68F5K-B:6H:9CC@DFCD9FHC:84CB
 :FCID75B585@A#88"5BMF9DFC8I7HC B-BD5FHC FK<C@9K#KCIHH9
 KF#88D9FA GGCBC:84CB:FCID75B585@A#88-GDFC<6#88"

F9J GCB H56@			
F9J "	97C	89G7 F-DHC B	85H9 5DDFC J 98
H	H	H	H H

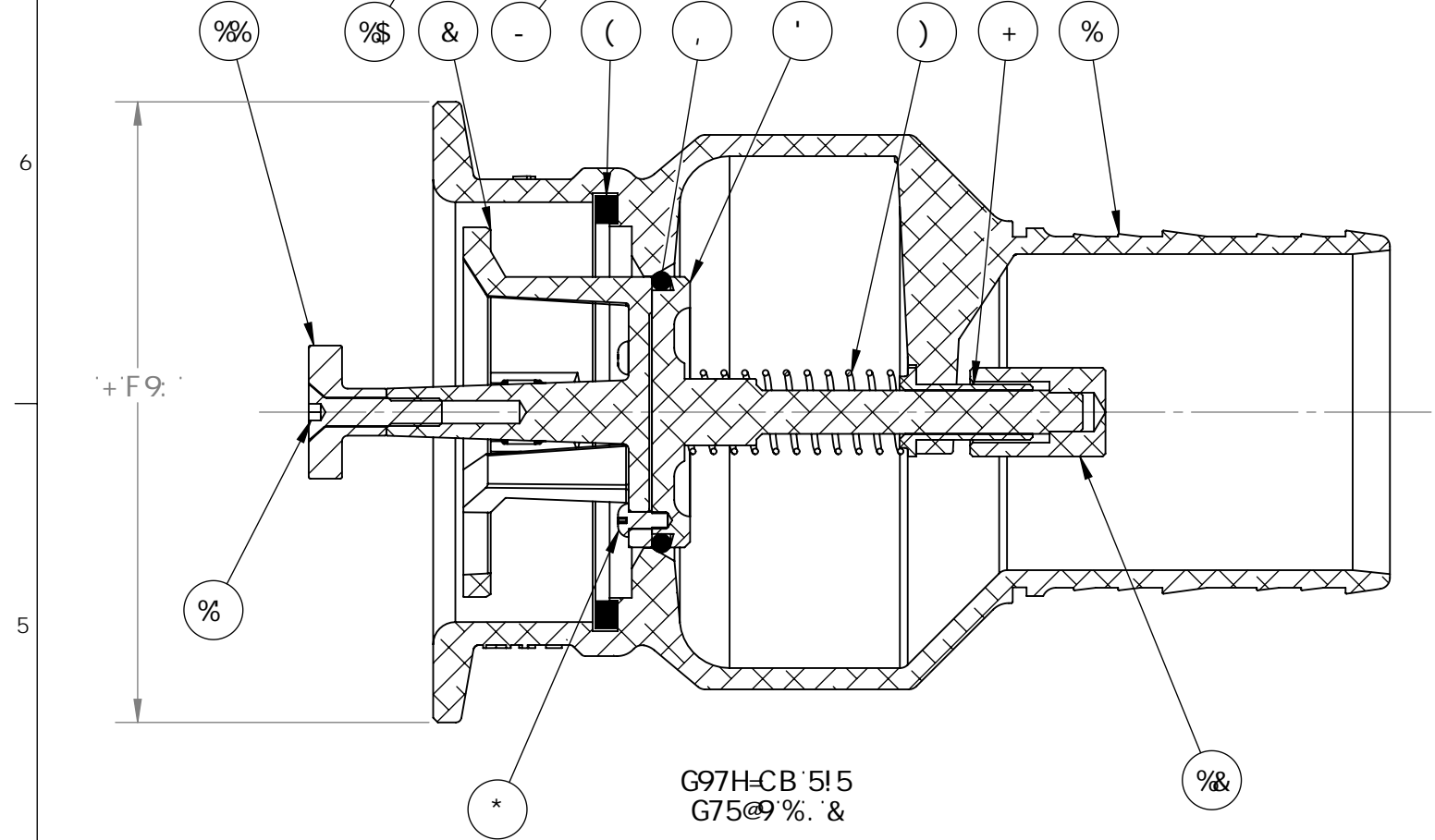
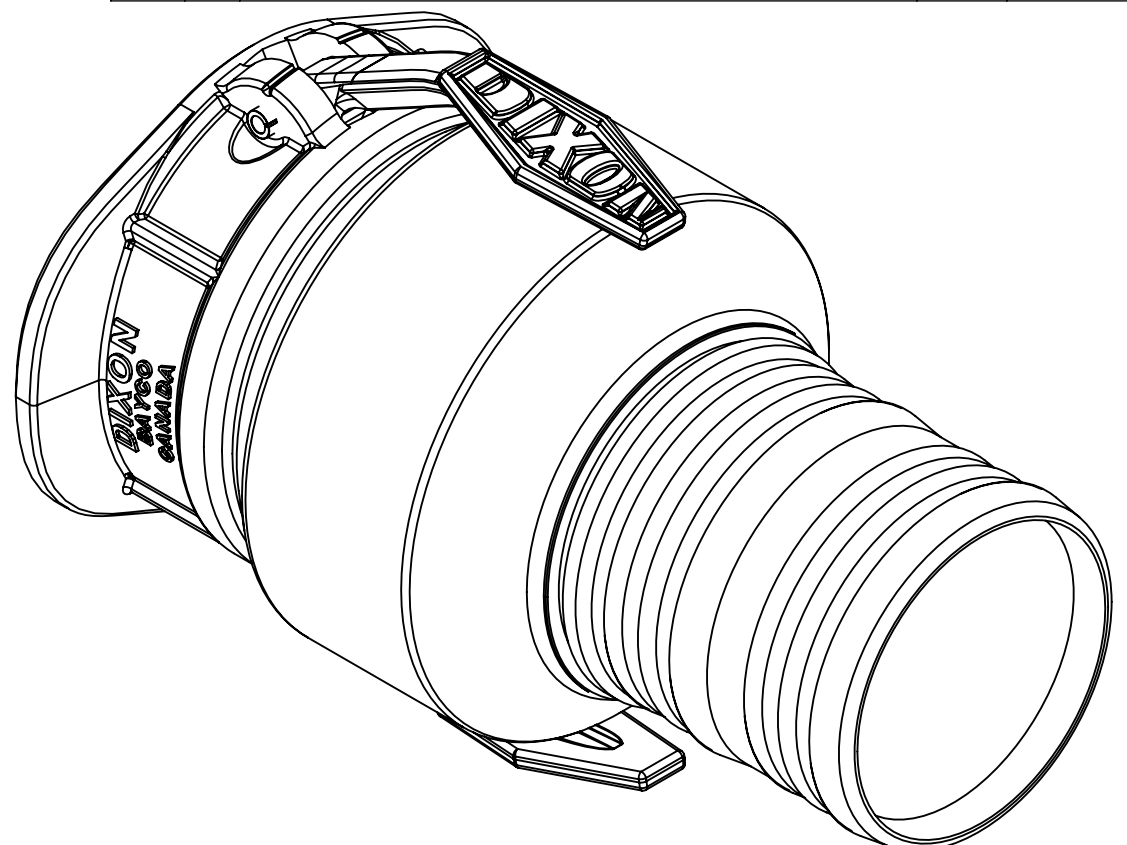
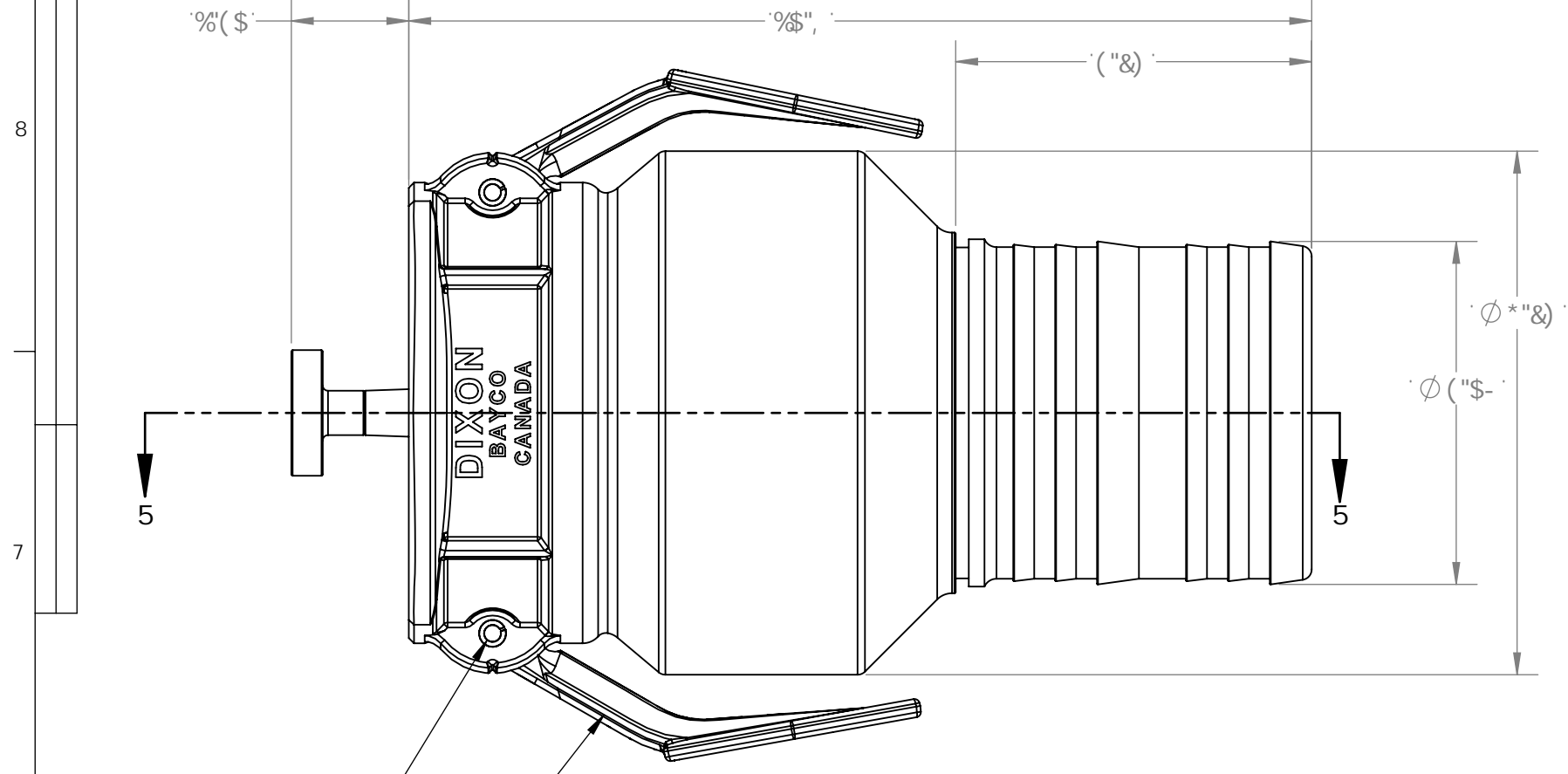

G97H-CB 5!5
 G75@9% .&

#9A 'BC "	D5FHBI A 69F	8 9G7 F-DHC B	E HM
%	' (% %	6C 8M	%
&	' (% %	75; 9	%
'	' (% &\$	DC DD9H	%
(%&&* &	; 5G?9H'f6I B5!BŁ	%
)	%&&*'	GDF-B;	%
*	%&&* (A 57 < -B 9G7 F9K	'
+	' - \$%(*	6I G<-B;	%
,	%&\$* - %	C!F-B; ; ' ' (fi?AŁ	%
-	(\$&%) GG	D588@9'5FA	&
%\$	(\$&%) GG	7 5A '5FA 'D-B	&
%&	' - % **	6I HHC B	%
%&	' - % *	DCDD9H'GHCD	%
%	%&(%*) #/%!% : @5H' < 958' GC7?9H'G7F9K	%

B A 9BGC BG 5F9 -B -B7 < 9G1 B@GG C H:9FK 69 CD97 * 98		<p>The Right Connection™</p>		FKZP'I TQWRECPFC'NKO KWGF &&\$@\$@: 5B'5J 9"K -BB-D9, ZA 6"F&F '\$-& D<C B 9f&\$ (Ł** '!) *) \$: 5L f&\$ (Ł** '! * %&	
758: 9B 9F 5H88 8F5K -B: /8C BCHA 5B1 5@M1 D85H9				J F (\$ (\$7 G5 @@ J 5DC F 7 C I D @F	
BC 'BCH G7 5@9' 8F5K -B:		5DDFC J 5@G		85H9	
A 5H9F-5@		8F5K B 6M @L "		G9D &- Z&\$%(
7 < 97 7 98		LLL		III	
				G89 BK: "BC"	
				6	
				97C	
				G:99H % C: %	